

**DEVILBISS AG360**

**Series: AG362**

**Low Pressure, Air Atomisation Automatic Spray Gun, with Lever or Screw Type Manifold.**

CE  II 2 G X T6

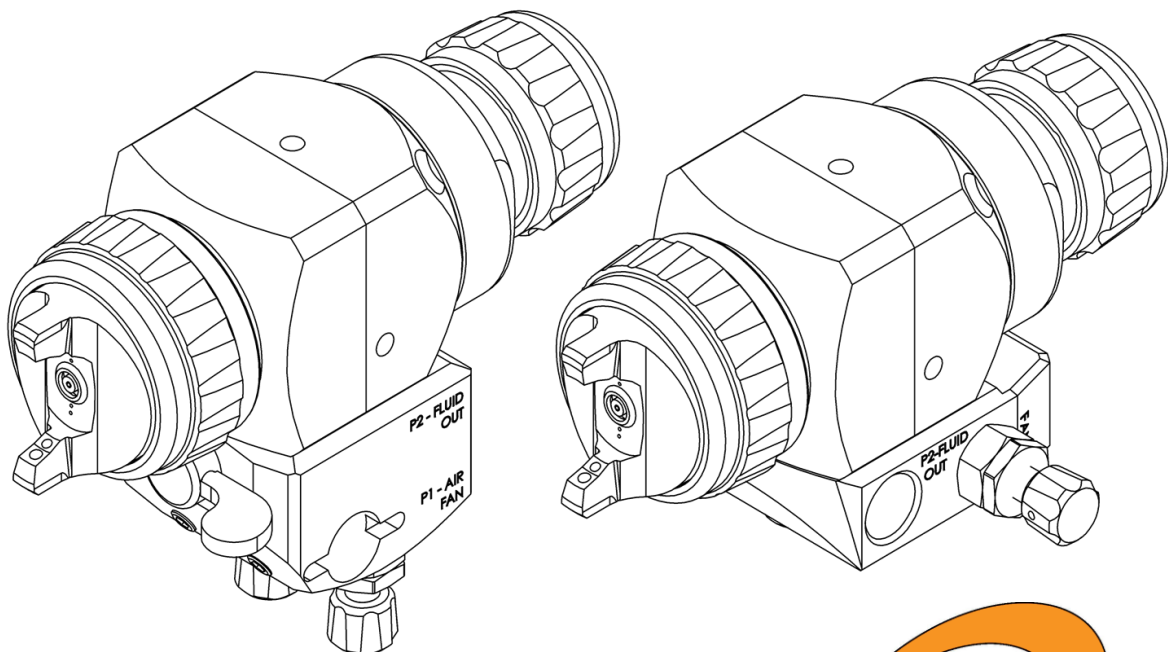

**IMPORTANT! DO NOT DESTROY**

It is the Customer's responsibility to have all operators and service personnel read and understand this manual.

Contact your local Devilbiss representative for additional copies of this manual.

**READ ALL INSTRUCTIONS BEFORE OPERATING THIS DEVILBISS PRODUCT.**

## FUNCTIONAL DESCRIPTION

The AG362 low pressure air atomising spray guns are designed to be fast changeover, modular construction applicators, for spray finishing on machines and fixed mountings.

The AG362 can be mounted on either a rear entry, lever operated, fast detachable manifold, or a screw attached, low profile manifold, dependant on the part number selected and mounting preference.

The AG362 is intended for most types of general industrial coating and fine finishing operations, suitable for both water based and solvent based applications.

Guns are available with a range of Conventional, Trans-Tech (High Efficiency) and HVLP atomisation air caps, to give a choice of atomisation and Transfer Efficiency parameters.

The gun is designed as a flexible solution for the modern coating applicator, with multiple accessories available, to further optimise the process.

## SPECIFICATIONS

FLUID AND AIR INLET PRESSURES	
P1= Max Air Input Pressure	7 Bar [102 psi]
P2= Max Fluid Input Pressure	7 Bar [102 psi]
P3= Cylinder Air Pressure	4 - 7 Bar [58 psi - 102 psi]

ENVIRONMENTAL	
Max Ambient Operating Temperature	40°C Nominal [104°F]

MATERIALS OF CONSTRUCTION	
Gun Head and Fluid Passageways	Stainless Steel
Gun Body Material	Quickclean™ Coated Aluminium
Air Cap Material	Electroless Nickel Plated Brass
Fluid Tip and Needle Construction	Stainless Steel Nitride Coated Stainless Steel
Seals and O-Rings	HDPE, Viton Extreme

MANIFOLD CONNECTIONS	LEVER TYPE	SCREW TYPE
P1= Air Inlet Size	1/8" G	1/4" G
P2= Fluid Inlet Size	1/8" G	1/4" NPS
P3= Cylinder Inlet	1/8" G	1/8" G

WEIGHT WITH MANIFOLD	LEVER TYPE	SCREW TYPE
WEIGHT	940g	850g

DIMENSIONS WITH MANIFOLD	LEVER TYPE	SCREW TYPE
L x H x W mm	127 x 97 x 44	127 x 64 x 89

**Product Description / Object of Declaration:** AG362

**This Product is designed for use with:** Solvent and water based materials

**Suitable for use in hazardous area:** Zone 1 / Zone 2

**Protection Level:** II 2 G X T6

**Notified body details and role:** Element Materials Technology (0891)  
Lodging of Technical file

**This Declaration of conformity / incorporation is issued under the sole responsibility of the manufacturer:** Carlisle Fluid Technologies UK Ltd,  
Ringwood Road,  
Bournemouth, BH11 9LH. UK

## EU Declaration of Conformity



**The object of the declaration described above is in conformity with the relevant Union harmonisation legislation:**

Machinery Directive 2006/42/EC

ATEX Directive 2014/34/EU

by complying with the following statutory documents and harmonised standards:

EN ISO 12100:2010 Safety of Machinery - General Principles for Design

BS EN 1953:2013 Atomising and spraying equipment for coating materials - Safety requirements

EN 1127-1:2011 Explosive atmospheres - Explosion prevention - Basic concepts

EN 13463-1:2009 Non electrical equipment for use in potentially explosive atmospheres - Basic methods and requirements

HVLP and High Efficiency products comply with the requirements of PG6 from the EPA guidelines and offer greater than 65% transfer efficiency.

Providing all conditions of safe use / installation stated within the product manuals have been complied with and also installed in accordance with any applicable local codes of practice.

Signed for and on behalf of Carlisle Fluid  
Technologies UK Ltd:

A handwritten signature in black ink, appearing to read 'D Smith'.

D Smith  
20/4/16

Director of Sales (EMEA)

⚠ <b>WARNING</b>	⚠ <b>CAUTION</b>	<b>NOTE</b>
Hazards or unsafe practices which could result in severe personal injury, death or substantial property damage.	Hazards or unsafe practices which could result in minor personal injury, product or property damage.	Important installation, operation or maintenance information.
⚠ <b>WARNING</b>		

Read the following warnings before using this equipment.



**SOLVENTS AND COATING MATERIALS.** Can be highly flammable or combustible when sprayed. Always refer to the coating material supplier's instructions and safety sheets before using this equipment.



**INSPECT THE EQUIPMENT DAILY.** Inspect the equipment for worn or broken parts on a daily basis. Do not operate the equipment if you are uncertain about its condition.



**READ THE MANUAL.** Before operating finishing equipment, read and understand all safety, operation and maintenance information provided in the operation manual. Users must comply with all local and national codes of practice and insurance company requirements governing ventilation, fire precautions, operation and house-keeping of working areas.



**EQUIPMENT MISUSE HAZARD.** Equipment misuse can cause the equipment to rupture, malfunction or start unexpectedly and result in serious injury.



**FIRE AND EXPLOSION HAZARD.** Never use 1,1,1-Trichloroethane, Methylene Chloride, other Halogenated Hydrocarbon solvents or fluids containing such solvents in equipment with aluminium wetted parts. Such use could result in a serious chemical reaction, with the possibility of explosion. Consult your fluid suppliers to ensure that the fluids being used are compatible with aluminium parts.



**GLOVES.** Must be worn when spraying or cleaning the equipment.



**WEAR SAFETY GLASSES.** Failure to wear safety glasses with side shields could result in serious eye injury or blindness.



**STATIC CHARGE.** Fluid may develop a static charge that must be dissipated through proper grounding of the equipment, objects to be sprayed and all other electrically conductive objects in the dispensing area. Improper grounding or sparks can cause a hazardous condition and result in fire, explosion or electric shock and other serious injury.



**WEAR RESPIRATOR.** The use of respiratory protective equipment is recommended at all times. The type of equipment must be compatible with the material being sprayed.



**TOXIC VAPOURS.** When sprayed, certain materials may be poisonous, create irritation, or are otherwise harmful to health. Always read all labels, safety sheets and follow any recommendations for the material before spraying. If in doubt contact your material supplier.



**NEVER MODIFY THE EQUIPMENT.** Do not modify the equipment unless the manufacturer provides written approval.



**LOCK OUT / TAG-OUT.** Failure to de-energise, disconnect, lock out and tag-out all power sources before performing equipment maintenance could cause serious injury or death.

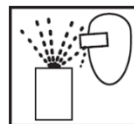

**PROJECTILE HAZARD.** You may be injured by venting liquids or gases that are released under pressure, or flying debris.



**NOISE LEVELS.** The A-weighted sound level of pumping and spray equipment may exceed 85 dB(A) depending on equipment settings. Actual noise levels are available on request. It is recommended that ear protection is worn at all times while equipment is in use.



**PRESSURE RELIEF PROCEDURE.** Always follow the pressure relief procedure in the equipment instruction manual.



**KNOW WHERE AND HOW TO SHUT OFF THE EQUIPMENT IN CASE OF AN EMERGENCY.**



**HIGH PRESSURE CONSIDERATION.** High pressure can cause serious injury. Relieve all pressure before servicing. Spray from the gun, hose leaks or ruptured components can inject fluid into your body and cause extremely serious injury.



**OPERATOR TRAINING.** All personnel must be trained before operating finishing equipment.

**IT IS THE RESPONSIBILITY OF THE EMPLOYER TO PROVIDE THIS INFORMATION TO THE OPERATOR OF THE EQUIPMENT.**

## AG362 GUN PART NUMBER FORMAT & PART SELECTION GUIDE

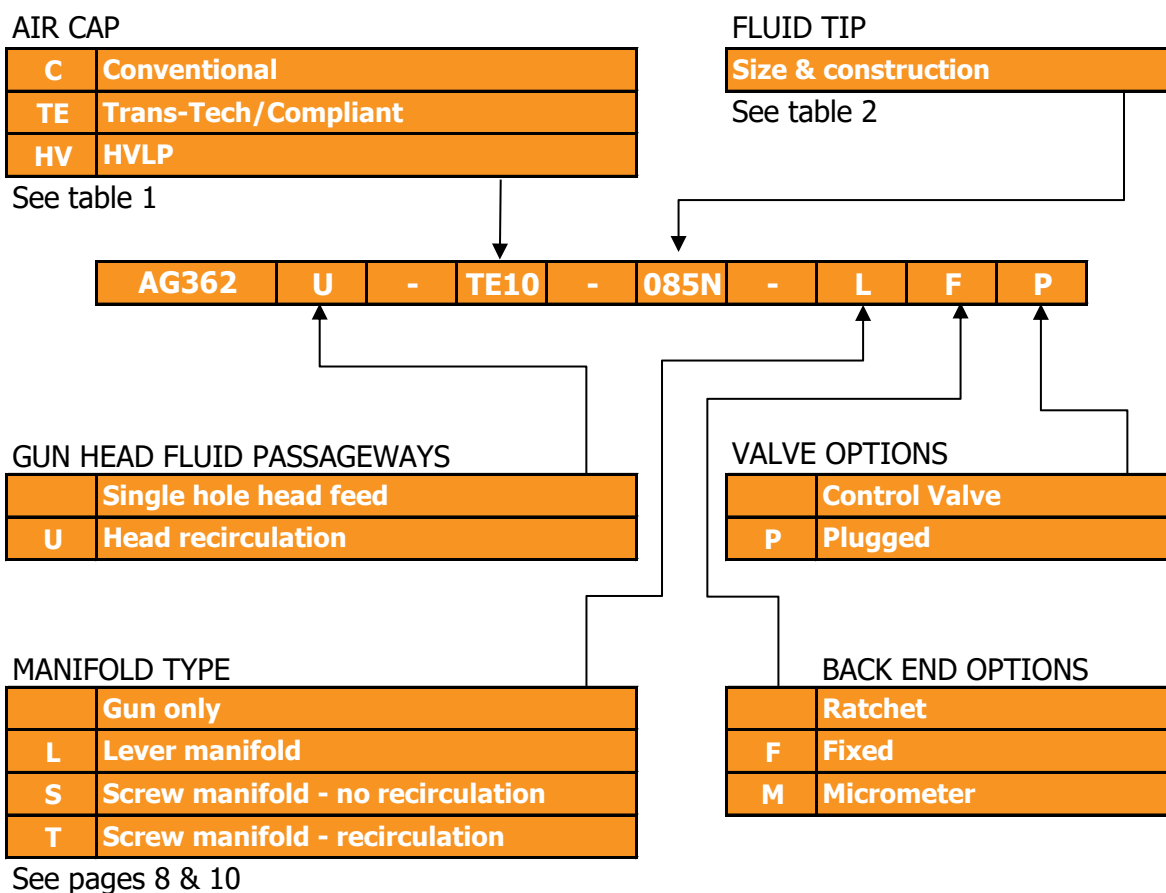
**TABLE 1****AG362 AIR CAP PERFORMANCE GUIDE**

Air Cap & Type		Part Number	Air Consumption	Recommended Air Inlet Pressure	Typical Fluid Flow*	Typical Fan Pattern Size**
C1	Conventional	PROC-120-C1-K	300 L/min [10.7 cfm]	3 Bar [45 psi]	150-250 ml/min	270mm
C2	Conventional	PROC-120-C2-K	290 L/min [10.3 cfm]	3 Bar [45 psi]	100-350 ml/min	270mm
C3	Conventional	PROC-120-C3-K	440 L/min [15.7 cfm]	3 Bar [45 psi]	250-600 ml/min	360mm
TE10	Trans-Tech/Compliant	PRO-100-TE10-K	255 L/min [9.1 cfm]	2 Bar [30 psi]	150-200 ml/min	300mm
TE20	Trans-Tech/Compliant	PRO-100-TE20-K	325 L/min [11.6 cfm]	2 Bar [30 psi]	150-200 ml/min	290mm
TE30	Trans-Tech/Compliant	PRO-100-TE30-K	375 L/min [13.3 cfm]	2 Bar [30 psi]	200-300 ml/min	300mm
TE40	Trans-Tech/Compliant	PRO-100-TE40-K	355 L/min [12.6 cfm]	2 Bar [30 psi]	250-400 ml/min	380mm
TE50	Trans-Tech/Compliant	PRO-100-TE50-K	425 L/min [15.1 cfm]	2 Bar [30 psi]	250-400 ml/min	300mm
HV30***	HVLP	PRO-100-HV30-K	450 L/min [16.0 cfm]	2 Bar [30 psi]	160-200 ml/min	315mm
R40	Trans-Tech/Compliant	PRO-102-R40-K	110 L/min [4.0 cfm]	3 Bar [30 psi]	150-300 ml/min	70mm

\* Flow rates may vary according to paint/material and pressure used.

\*\* Fan pattern size @ 200mm distance.

\*\*\* HV30 (HVLP) operates at 0.7 bar [10 psi] atomisation air pressure at the cap.

TABLE 2

AG362 RECOMMENDED FLUID TIP / AIR CAP COMBINATIONS												
AIR CAP	Atomisation Type	0.5mm	0.7mm	0.85mm	1.0mm	1.2mm	1.4mm	1.6mm	1.8mm	2.0mm	2.2mm	2.8mm
C1	Conventional	-	-	SN	SN	SN	SN	SN	SN	-	-	-
C2	Conventional	-	-	SN	SN	SN	SN	SN	SN	-	-	-
C3	Conventional	-	-	SN	SN	SN	SN	SN	SN	-	-	-

For Conventional tip & needle part numbers, see table 3.

TE10	Trans-Tech	-	-	SN	SN	SN	SN	SN	SN	SN	SN	-
TE20	Trans-Tech	-	-	SN	SN	SN	SN	SN	SN	SN	SN	-
TE30	Trans-Tech	-	-	SN	SN	SN	SN	SN	SN	SN	SN	-
TE40	Trans-Tech	-	-	SN	SN	SN	SN	SN	SN	SN	SN	-
TE40R	Trans-Tech	-	-	SN	SN	SN	SN	SN	SN	SN	SN	-
HV30	HVLP	-	-	SN	SN	SN	SN	SN	SN	SN	SN	-
R40	Trans-Tech	-	-	SN	SN	SN	SN	SN	SN	SN	SN	-

For Trans-Tech / HVLP tip & needle part numbers, see table 4.

S = High quality stainless steel tips & needles available in this type & size.

N = Nitride hardened tips & needles also available in this type & size.

TABLE 3

AG362 CONVENTIONAL FLUID TIPS & NEEDLES				
Fluid Tip Size	Stainless Steel		Nitride Hardened	
	Fluid Tip	Needle	Fluid Tip	Needle
0.85	PROC-215-085-K	SPA-362-085-10-K	PROC-215N-085-K	SPA-362N-085-10-K
1.0	PROC-215-10-K		PROC-215N-10-K	
1.2	PROC-215-12-K	SPA-362-12-14-K	PROC-215N-12-K	SPA-362N-12-14-K
1.4	PROC-215-14-K		PROC-215N-14-K	
1.6	PROC-215-16-K	SPA-362-16-18-K	PROC-215N-16-K	SPA-362N-16-18-K
1.8	PROC-215-18-K		PROC-215N-18-K	

TABLE 4

AG362 TRANS-TECH / HVLP FLUID TIPS & NEEDLES				
TABLE 3	Stainless Steel		Nitride Hardened	
	Fluid Tip	Needle	Fluid Tip	Needle
0.85	PRO-205-085-K	SPA-362-085-10-K	PRO-205N-085-K	SPA-362N-085-10-K
1.0	PRO-205-10-K		PRO-205N-10-K	
1.2	PRO-205-12-K	SPA-362-12-14-K	PRO-205N-12-K	SPA-362N-12-14-K
1.4	PRO-205-14-K		PRO-205N-14-K	
1.6	PRO-205-16-K	SPA-362-16-18-K	PRO-205N-16-K	SPA-362N-16-18-K
1.8	PRO-205-18-K		PRO-205N-18-K	
2.0	PRO-205-20-K	SPA-362-20-22-K	PRO-205N-20-K	SPA-362N-20-22-K
2.2	PRO-205-22-K		PRO-205N-22-K	

**TYPICAL AIR CONNECTION SCHEMATIC - LEVER TYPE MANIFOLD**

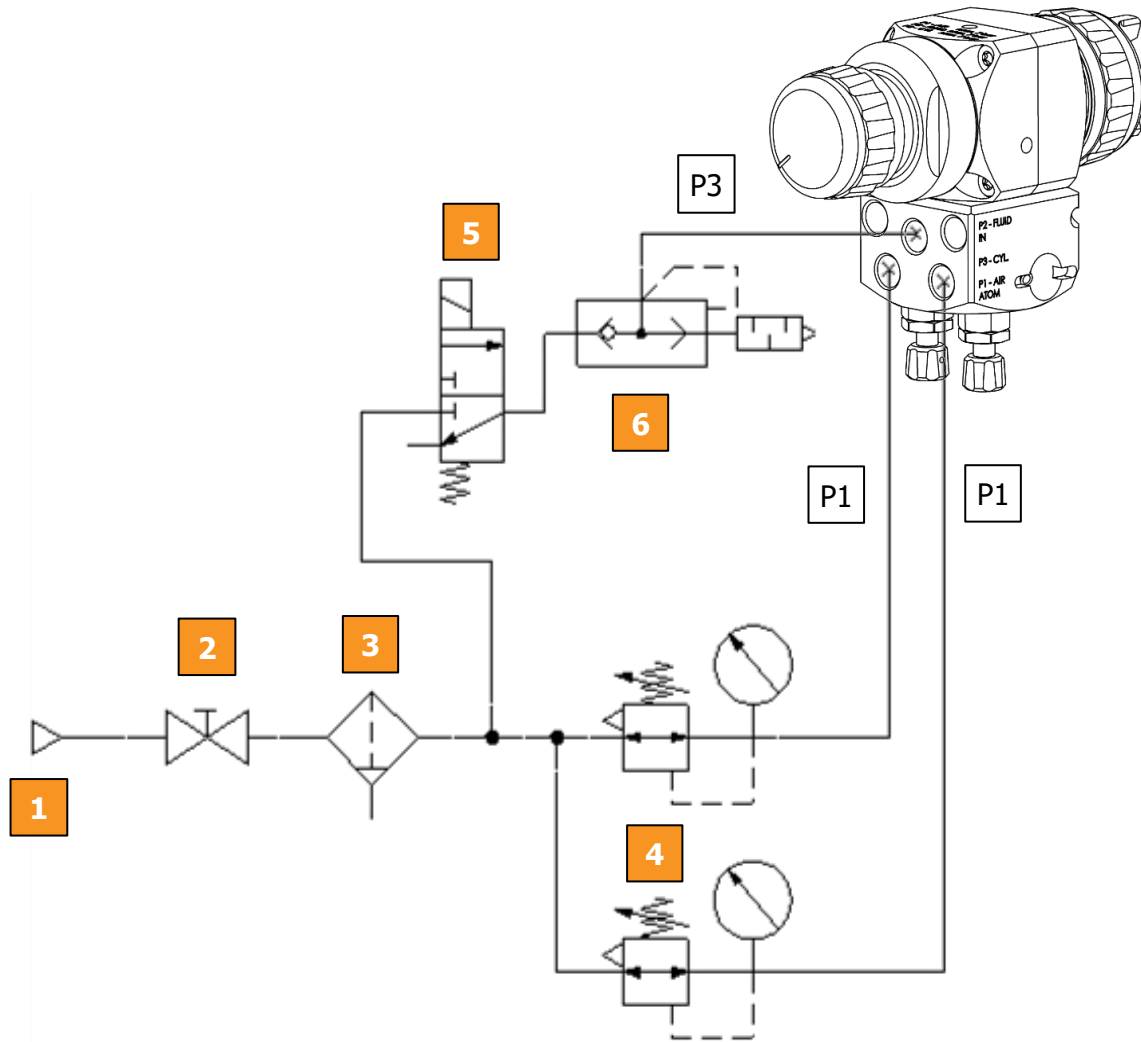

1	Compressed air take-off
2	Shut-off valve
3	Air filter
4	Air regulator & gauge
5	3/2 solenoid valve, normally closed
6	Quick exhaust valve & silencer
P1	CAP - 1/8" G
P3	CYL - 1/8" G



**WARNING**

The spray gun must be earthed to dissipate any electrostatic charges which may be created by fluid or air flows. This can be achieved through the spray gun mounting, or conductive air/fluid hoses. Electrical bond from the spray gun to earth should be checked and a resistance of less than 10<sup>6</sup> Ohms is required.

**TYPICAL FLUID CONNECTION SCHEMATIC - LEVER TYPE MANIFOLD**

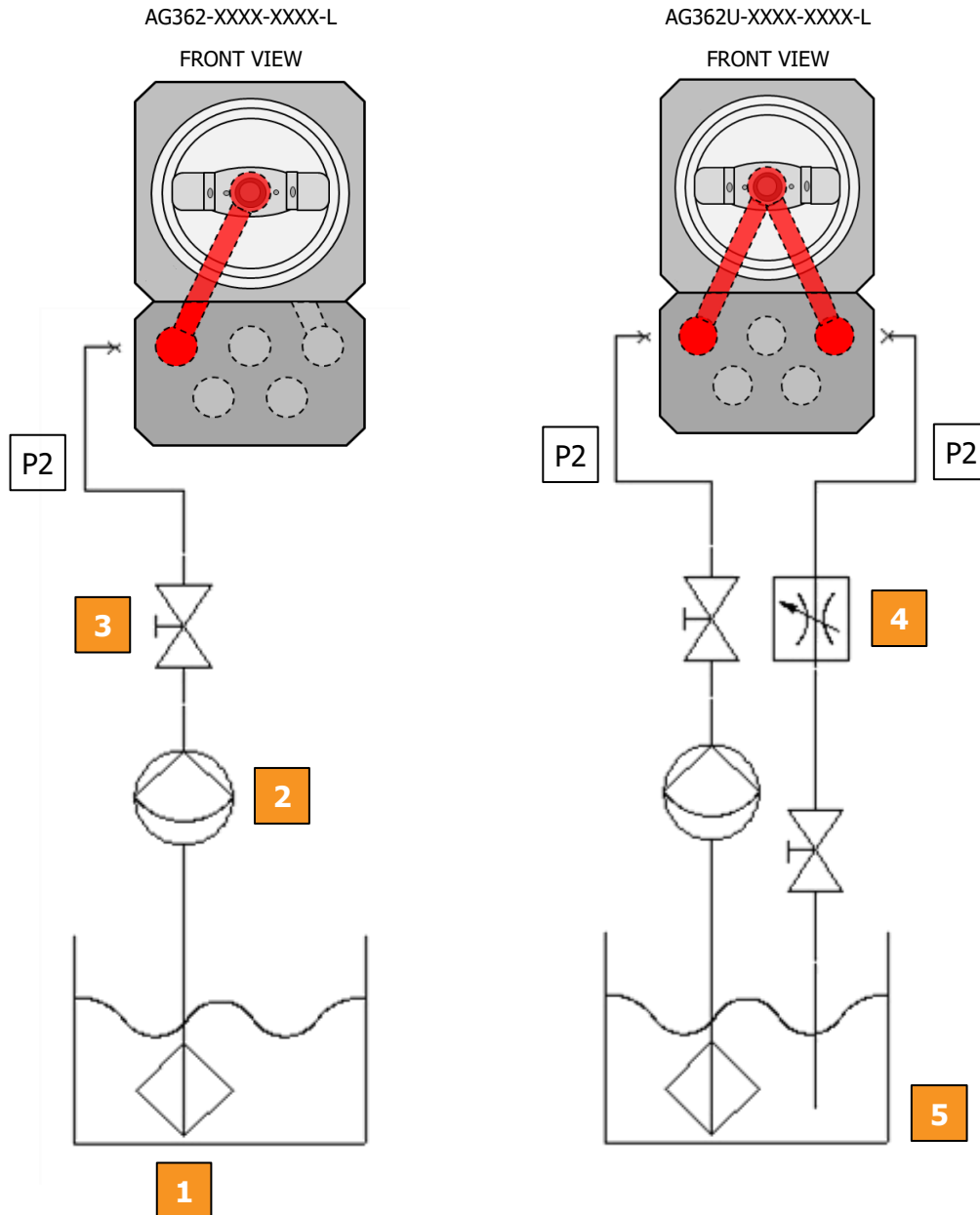

1	Fluid filter
2	Fluid supply
3	Shut-off valve
4	Fluid restrictor valve
5	Fluid reservoir
P2	Fluid - 1/8" G

**NOTE**

Protective coatings have been used for storage protection. Flush the equipment fluid passageways with appropriate solvent before use.



## TYPICAL FLUID CONNECTION SCHEMATIC - SCREW TYPE MANIFOLD

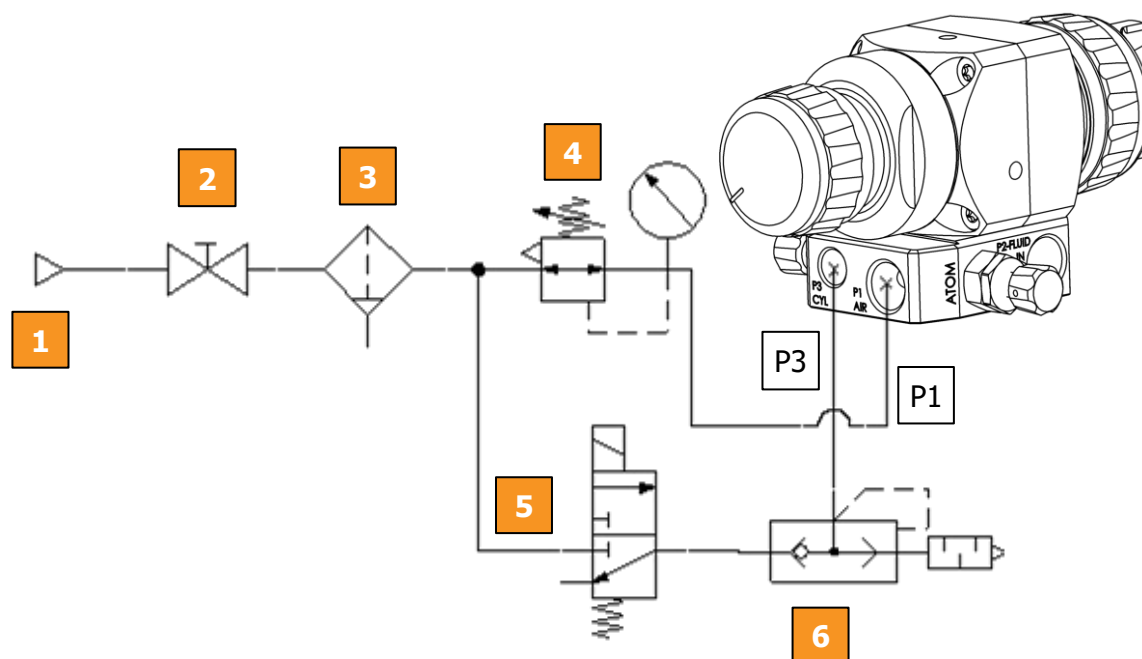

1	Compressed air take-off
2	Shut-off valve
3	Air filter
4	Air regulator & gauge
5	3/2 solenoid valve, normally closed
6	Quick exhaust valve & silencer
P1	CAP - 1/4" G
P3	CYL - 1/8" G

**WARNING**

The spray gun must be earthed to dissipate any electrostatic charges which may be created by fluid or air flows. This can be achieved through the spray gun mounting, or conductive air/fluid hoses. Electrical bond from the spray gun to earth should be checked and a resistance of less than  $10^6$  Ohms is required.

**TYPICAL FLUID CONNECTION SCHEMATIC - SCREW TYPE MANIFOLD**

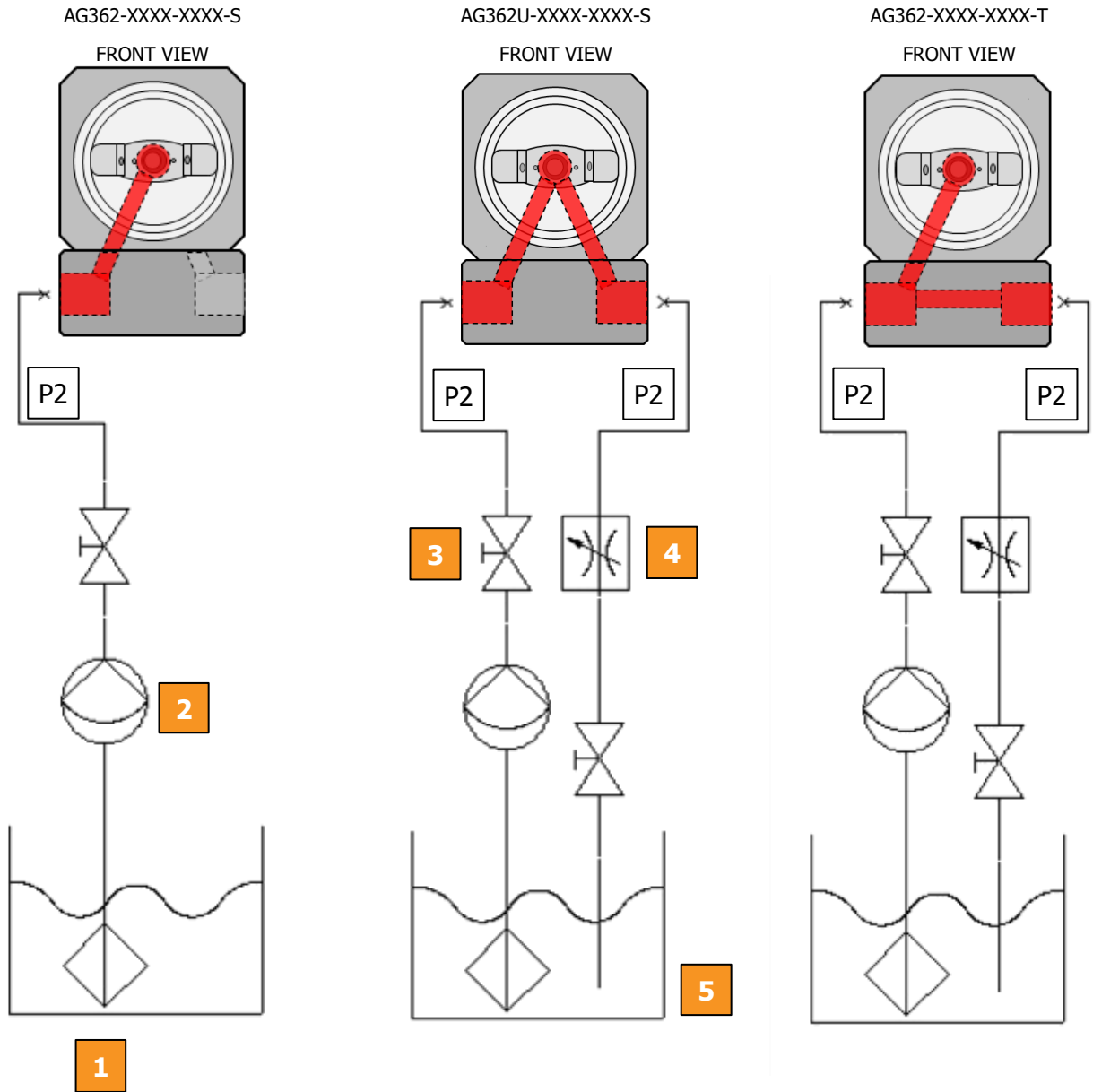

1	Fluid filter
2	Fluid supply
3	Shut-off valve
4	Fluid restrictor valve
5	Fluid reservoir
P2	Fluid - 1/4" NPS

**NOTE**

Protective coatings have been used for storage protection. Flush the equipment fluid passageways with appropriate solvent before use.

SPRAY GUN AND MANIFOLD INSTALLATION

AG362 - LEVER TYPE MANIFOLD

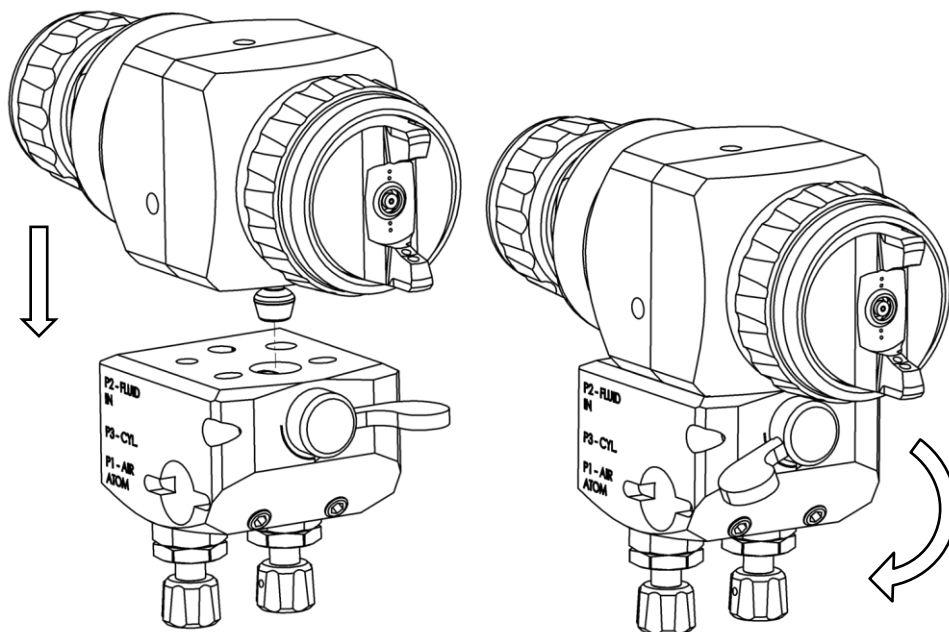

AG362 - SCREW TYPE MANIFOLD

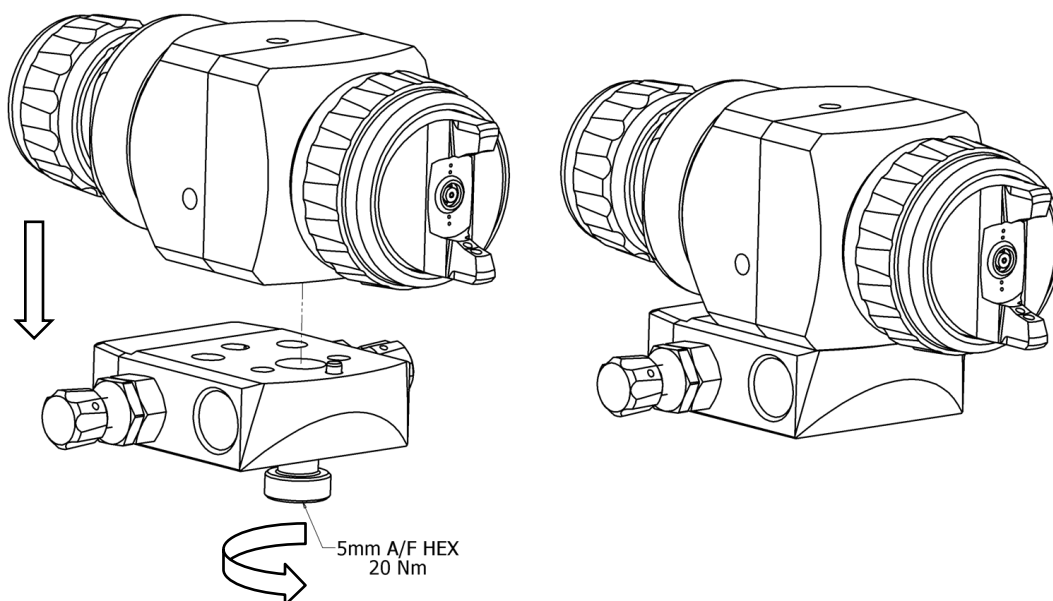

**EXPLODED VIEW**

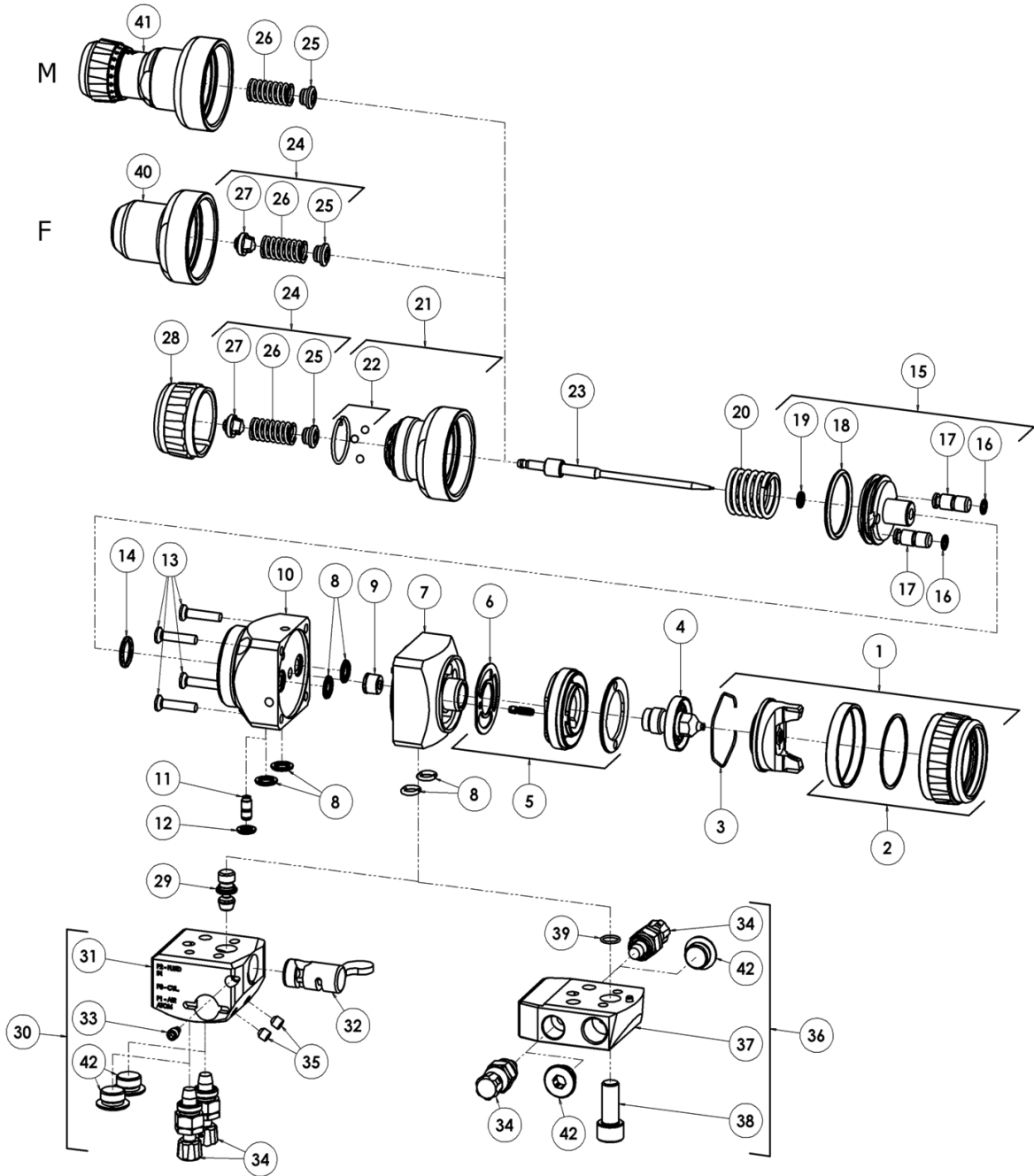

**PARTS LIST**

REF.	PART No.	DESCRIPTION	ASSEMBLY QTY.
1	SEE TABLE	AIR CAP & RETAINING RING	1
2	PRO-405-K	RETAINING RING SUB ASSEMBLY	1
3	JGA-156-K5	SPRING CLIP (KIT OF 5)	1
4	DESCRIPTION	FLUID TIP	1
5	SN-69-K	SPRAYHEAD & PIN ASSY	1
6	SN-18-1-K2	GASKET (KIT OF 2)	1
7	SPA-152-K	HEAD	1
	SPA-152U-K	RECIRCULATION HEAD	1

## PARTS LIST

REF.	PART No.	DESCRIPTION	ASSEMBLY QTY.
8	SPA-29X-K4	O RING (KIT OF 4)	6
9	SPA-159-K	NEEDLE PACKING	1
10	SPA-153-K	BODY	1
11	SPA-52	AIR TUBE	1
12	S-28223X-K4	O RING (KIT OF 4)	1
13	S-14192-K4	TORX SCREW (KIT OF 4)	4
14	S-28220X-K2	O RING (KIT OF 2)	1
15	SPA-60X-K	PISTON & SEAL KIT	1
16	S-28224X-K4	O RING (KIT OF 4)	2
17	SPA-62-K2	AIR VALVE PISTON (KIT OF 2)	2
18	S-28225X-K2	O RING (KIT OF 2)	1
19	S-28219X-K4	O RING (KIT OF 4)	1
20	SPA-13	PISTON SPRING	1
21#	SPA-415-K	REAR HOUSING ASSEMBLY	1
22	SPA-KK-1	RING AND BALL KIT	1
23	SEE TABLE	FLUID NEEDLE	1
24	SPA-421-K	NEEDLE SPRING KIT	1
25	SPA-422-K2	SPRING COLLAR (KIT OF 2)	1
26	SPA-31	NEEDLE SPRING	1
27	SPA-165-K2	SPRING BUTTON (KIT OF 2)	1
28#	SPA-166-K	ADJUSTING KNOB	1
29*	SPA-160-K	LOCKING PIN (AG-362)	1
30	SPA-418-K	LEVER MANIFOLD ASSEMBLY	1
	SPA-418P-K	LEVER MANIFOLD ASSEMBLY PLUGGED	1
31	-	MANIFOLD	1
32	SPA-424-K	LOCKING CAM	1
33*	SPA-59	RETAINING SCREW	1
34	SPA-414-K	CONTROL VALVE	2
35	S-14193	HEXAGON SOCKET SET SCREW	2
36	SPA-419-K	SCREW MANIFOLD ASSEMBLY	1
	SPA-419U-K	RECIRCULATION SCREW MANIFOLD ASSEMBLY	1
	SPA-419P-K	SCREW MANIFOLD ASSEMBLY PLUGGED	1
	SPA-419UP-K	RECIRCULATION SCREW MANIFOLD ASSEMBLY PLUGGED	1
37	-	MANIFOLD	1
38	SPA-161-K2	CLAMPING SCREW (KIT OF 2)	1
39	-	O-RING (PART OF SPA-161-K2)	1
40	SPA-167-K	FIXED REAR HOUSING	1
41	SPA-417-K	MICROMETER ASSEMBLY	1
42	SPA-111-K2	BLANKING PLUG	2

\* PART OF KIT SPA-424-K

# PART OF KIT SPA-426-K

---





## TYPICAL SETTING

1. The ATOM air valve controls the atomising air pressure, the FAN valve controls the spray pattern size. To increase the pressure, turn anti-clockwise and to reduce the pressure turn clockwise.
2. Fluid flow can be adjusted with the needle adjustment knob, fluid flow is increased when you turn the knob anti-clockwise.

## TYPICAL START-UP SEQUENCE

1. Turn the needle adjustment knob anti-clockwise until the needle is fully open.
2. Turn the FAN and ATOM air valves anti-clockwise to be fully open.
3. Trigger the gun and adjust the fluid supply pressure, to obtain the recommended fluid flow shown in the air cap performance guide table.
4. Trigger the gun and set the gun inlet air pressure regulator, to achieve the recommended start pressures, shown in the air cap performance guide table.
5. Test spray - if the finish is too dry or fine, reduce the air flow by reducing the air inlet pressure or by screwing the ATOM valve in clockwise. Alternatively increase the fluid flow using the fluid supply pressure.
6. Test spray - if the finish is too wet, reduce the fluid supply pressure to reduce the fluid flow. Alternatively increase the air inlet pressure to increase atomising pressure.
7. Use the needle adjustment knob for final fine tuning of the fluid flow.
8. The pattern size can be reduced by turning adjusting valve clockwise. A reduction in the spray fan may require a reduction in fluid flow.
9. The spray pattern will be optimised when the spray gun is perpendicular to the target.
10. The recommended spray distance is normally 150-200mm. [6-8"]
11. Always turn off air and fluid supply, relieve pressure and clean down when gun is not in use.

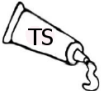
MAINTENANCE

KEY - MAINTENANCE SYMBOLS	
	Order for disassembly <i>(reverse for assembly)</i>
#	Item Number
	Petroleum Grease/Jelly
	Thread Sealant
	Thread Locker

DISASSEMBLY TIP & NEEDLE

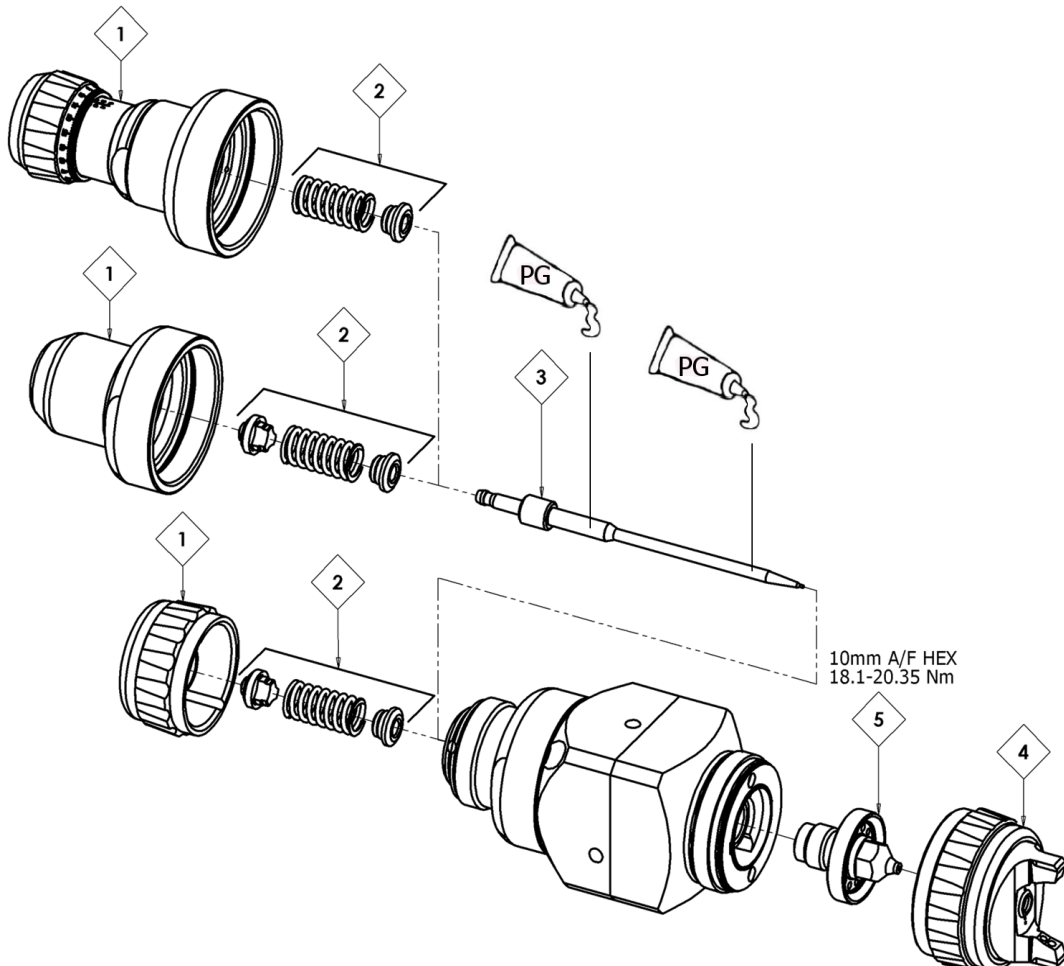

**DISASSEMBLY PACKING**

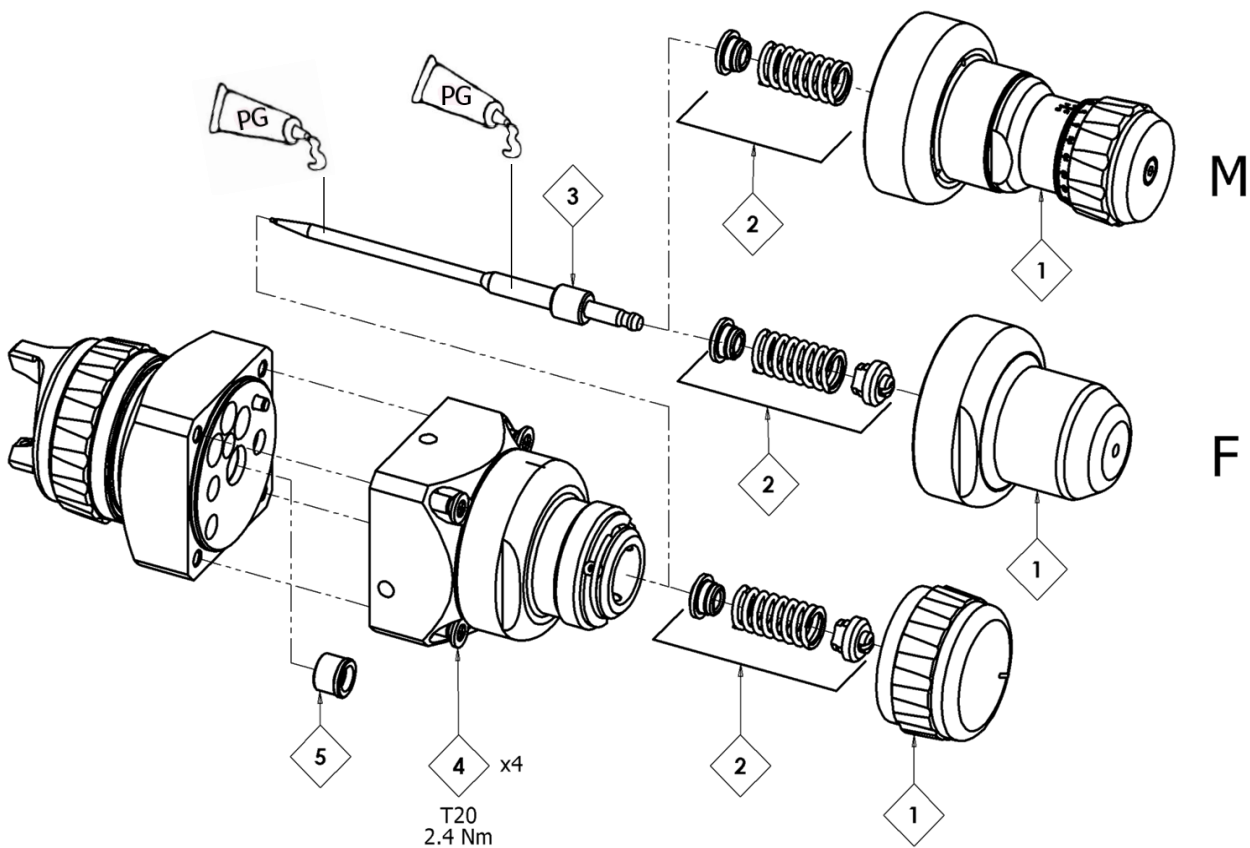

**DISASSEMBLY PISTON**

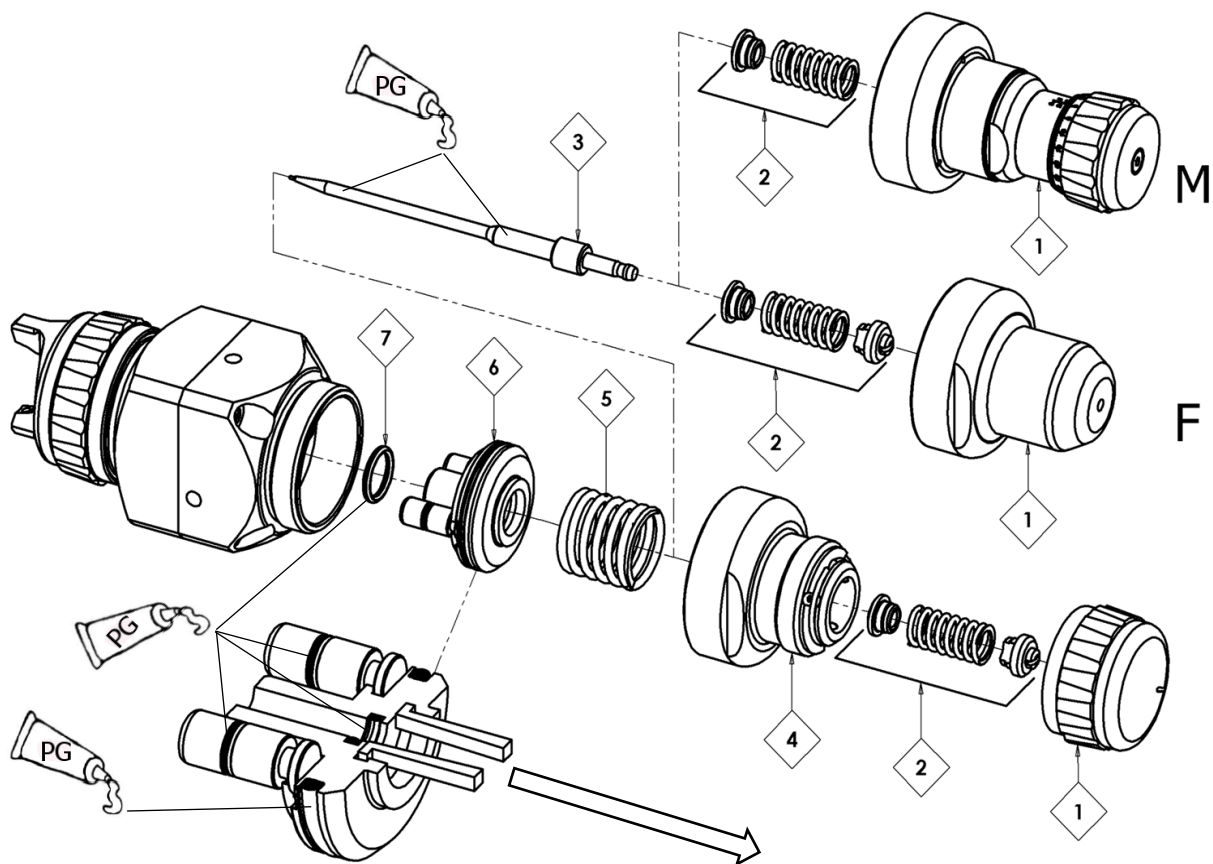



**TROUBLESHOOTING MECHANICAL PERFORMANCE**

GENERAL FAULTS	CAUSE	CORRECTION
Will not spray.	No air pressure at gun.	Check air supply and air line.
	Fluid needle adjustment knob not open enough.	Open fluid needle adjustment knob.
Gun spits paint when triggering on and off.	Incorrect needle fitted to gun.	Check tip/needle selection chart and fit correct item.
	Excessive needle wear.	Replace with new needle.
	Excessive fluid tip wear.	Replace with new fluid tip.
Gun spits paint when triggering on due to paint build-up inside air cap between spraying operations.	Fluid tip not fitted correctly in gun head.	Tighten.
	Fluid tip/needle leakage.	Check for damage or blockage.
Paint build-up on fluid tip.	Fluid tip not fitted correctly in gun head.	Tighten.
	Fluid tip/needle leakage.	Check for damage or blockage.
Paint build-up on air cap.	Damaged air cap holes.	Replace with new air cap.
	Gradual build-up of bounce-back on gun head.	Thoroughly clean.
Unable to get round spray	Fluid tip or sprayhead incorrectly fitted.	Remove, check components for damage and refit correctly.

When removing air cap from retaining ring, do not remove the ring seat from the retaining ring. Damage to the parts may occur. Simply wipe parts clean and reassemble with new or clean air cap.

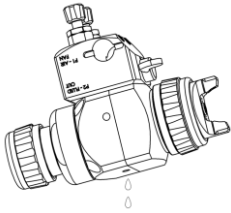
FLUID FAULTS	CAUSE	CORRECTION
Slow fluid leak from fluid tip and needle seat.	Fluid tip internal seat scored damaged or worn.	Replace.
	Fluid needle external profile damaged or worn.	Replace.
	Contamination on needle or tip mating surfaces preventing good seal.	Thoroughly clean.
	Incorrect fluid tip for fluid needle fitted to gun.	Check tip/needle selection chart and fit correct item.
	Sluggish needle.	Lubricate packing.
	Tight packing nut.	Adjust.
Major fluid leak or fluid jetting from fluid tip and needle seat.	Contamination on needle or tip mating surfaces preventing good seal.	Remove tip and needle and thoroughly clean.
	Incorrect fluid tip for fluid needle fitted to gun.	Check tip/needle selection chart and fit correct item.
Slow fluid leak from needle packing, three possible places. 	Fluid needle packing worn or loose.	Tighten or replace as necessary.
AIR FAULTS	CAUSE	CORRECTION
Small air leak from air cap when gun is not triggered.	Piston contaminated and not correctly seating.	Remove piston and thoroughly clean valve shaft and seating surfaces.
	Piston seal damaged or missing.	Replace.

**LEVER TYPE MANIFOLD FAULTS**

ASSEMBLY FAULTS	CAUSE	CORRECTION
Spray gun does not locate onto manifold.	Locking cam is not in the unlock position.	Turn locking cam lever to unlock position on manifold.
Spray gun is loose when assembled onto manifold.	Locking cam has not been tightened.	Turn locking cam lever to lock position on manifold.
	Locking cam has worn.	Replace using locking cam kit SPA-424-K
Spray gun cannot be removed from manifold.	Locking cam is not in the unlock position.	Turn locking cam lever to unlock position on manifold.

**SCREW TYPE MANIFOLD FAULTS**

ASSEMBLY FAULTS	CAUSE	CORRECTION
Spray gun does not locate onto manifold.	Item 29 - locking pin still in place.	Remove item 29 - locking pin.
Spray gun is loose when assembled onto manifold.	Clamping screw has not been tightened.	Tighten screw.
	Clamping screw has worn.	Replace using clamping screw kit SPA-161-K2.
Spray gun cannot be removed from manifold.	Clamping screw still in place.	Remove clamping screw.

## TROUBLESHOOTING SPRAY PERFORMANCE

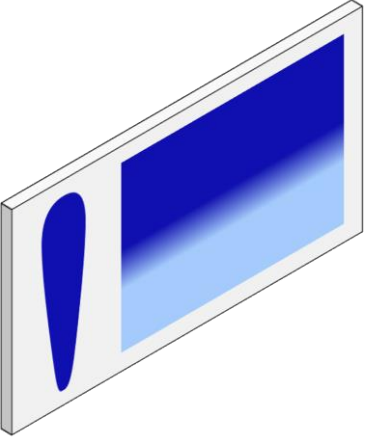
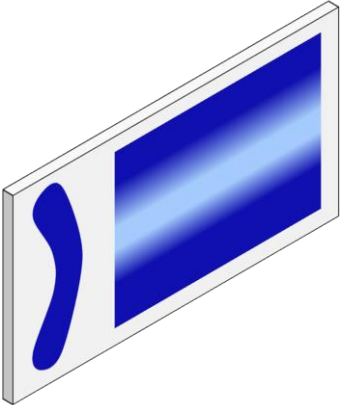
CONDITION	CAUSE	CORRECTION
Heavy top or bottom pattern. 	Material build-up on air cap, plugged horn holes, centre holes or jets.	Soak cap or tip in suitable solvent and thoroughly clean.
	Material build-up on fluid tip exterior or partially plugged fluid tip.	Replace fluid tip or air cap if necessary.
	Fluid tip or cap dirty or damaged.	Replace fluid tip or air cap if necessary.
Heavy right or left side pattern. 	Left or right side horn holes plugged.	Soak cap or tip in suitable solvent and thoroughly clean.
	Dirt or damage on left or right side of fluid tip exterior.	Replace fluid tip or air cap if necessary.
Remedies for the top-heavy, bottom-heavy, right-heavy and left-heavy patterns.		
<p>Determine if the obstruction is on the air cap or the fluid tip. Do this by making a test spray pattern. Then, rotate the cap one-half turn and spray another pattern. If the defect is inverted, obstruction is on the air cap. Clean the air cap as previously instructed. Also check for dried paint just inside the cap centre hole opening, remove by washing with solvent.</p>		
<p>If the defect is not inverted, it is on the fluid tip. Clean tip. If problem persists, renew tip.</p>		

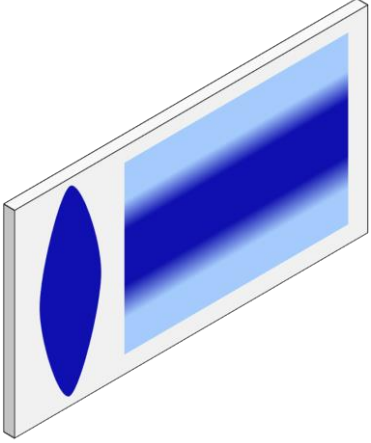
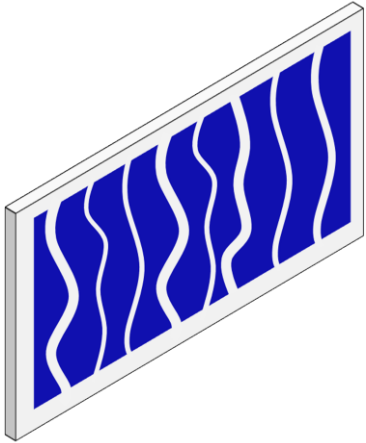
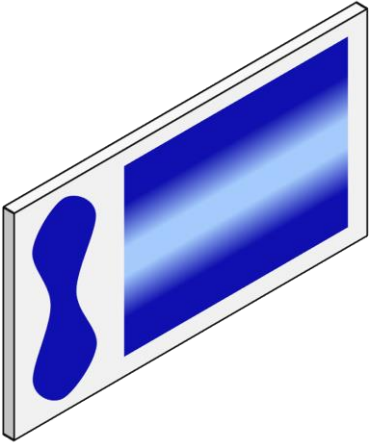
<p>Heavy centre pattern.</p> 	<p>Pattern adjustment valve set too low.</p>	<p>Turn out counter clockwise to achieve correct pattern.</p>
	<p>Too much material.</p>	<p>Reduce fluid flow by turning fluid needle adjusting screw clockwise. Reduce fluid pressure.</p>
	<p>Material too thick.</p>	<p>Thin to correct consistency.</p>
	<p>Atomising air pressure too low.</p>	<p>Increase air pressure.</p>
<p>Intermittent or 'fluttering' spray fan.</p> 	<p>Loose fluid tip.</p>	<p>Tighten.</p>
	<p>Fluid tip not seated correctly in gun head.</p>	<p>Remove fluid tip, clean components, check cone seating on tip and gun for damage or contamination.</p>
	<p>Partially obstructed fluid passage or hose.</p>	<p>Clean or replace.</p>
<p>Split spray pattern</p> 	<p>Not enough material flow.</p>	<p>Increase fluid flow by changing fluid tip size, opening needle control knob or increase fluid pressure on pressure feed container.</p>
	<p>Too high horn pressure.</p>	<p>Reduce air pressure by rotating pattern control valve clockwise.</p>
	<p>Too much air for fluid quantity used.</p>	<p>Reduce input air pressure.</p>

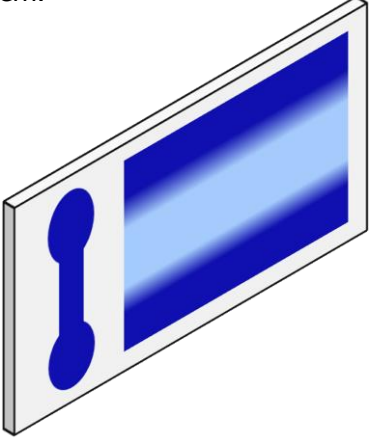
<p>Ball end heavy pattern.</p> 	<p>Too much fluid flow.</p>	<p>Change fluid tip for smaller size or change air cap for different specification air cap.</p>
<p>Excessive bounce-back.</p>	<p>Too much atomisation air pressure.</p>	<p>Reduce air pressure.</p>
	<p>Gun too far from surface.</p>	<p>Check distance (normally 150-200mm).</p>
<p>Runs and sags.</p>	<p>Too much fluid flow.</p>	<p>Adjust gun or reduce fluid pressure.</p>
	<p>Material too thin.</p>	<p>Mix properly or apply light coats/reduce fluid flow.</p>
	<p>Gun tilted at an angle.</p>	<p>Mount gun at right angle to work.</p>
<p>Thin, sandy coarse finish drying before it flows out.</p>	<p>Gun too far from surface.</p>	<p>Check distance.</p>
	<p>Too much air pressure.</p>	<p>Reduce air pressure and check spray pattern.</p>
	<p>Fluid flow too low.</p>	<p>Increase fluid flow by changing fluid tip size, supply pressure or turning needle control knob counter clockwise.</p>

**MOUNTING ADAPTOR OPTIONS - SCREW TYPE MANIFOLD**

SPA-173-K

Horizontal mounting bar and screws

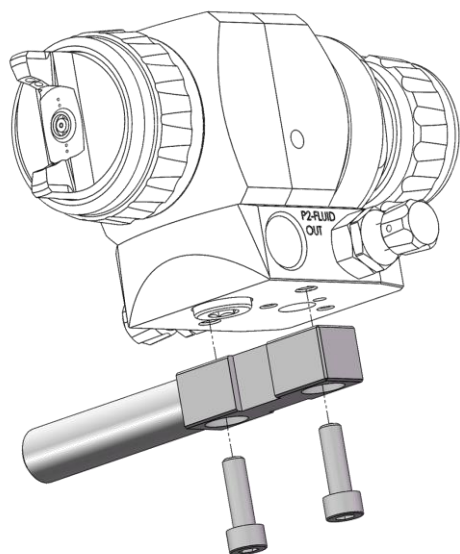

SPA-174-K

Vertical mounting bar and screws

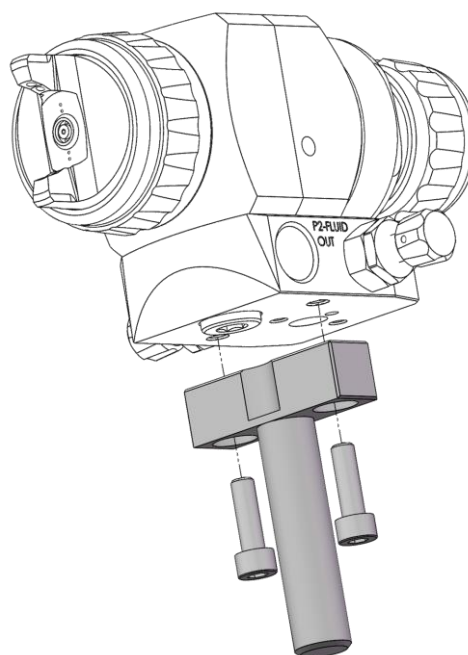

SPA-175-K

Mounting block and screws

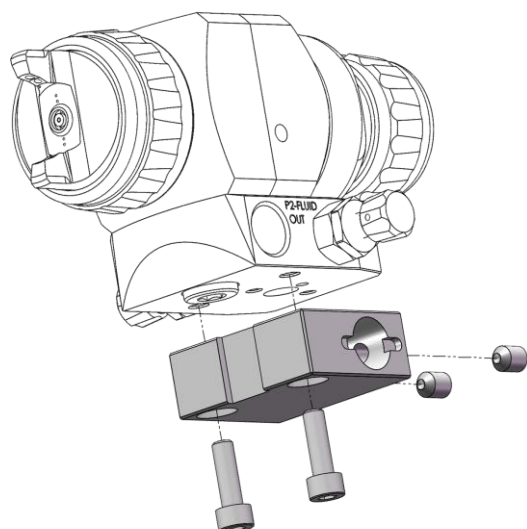





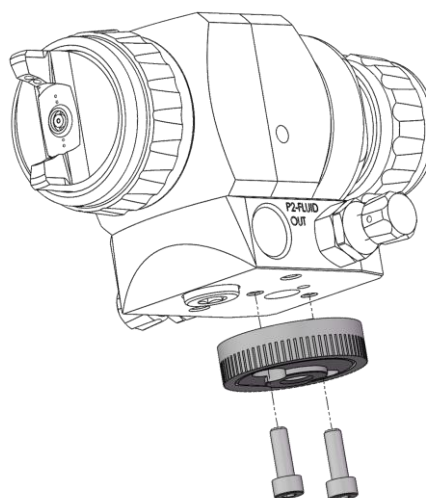



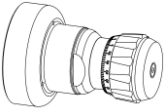
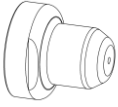
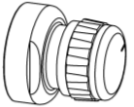

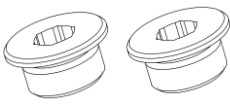
SPA-176-K

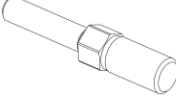
Index adjustment and screws

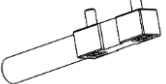

## ACCESSORIES

PART No.	DESCRIPTION	
SPA-417-K	Micrometer needle adjustment assembly.	
SPA-167-K	Fixed needle position end cap.	
SPA-426-K	Ratchet needle adjustment assembly.	
SPA-414-K	Control Valve	
SPA-111-K2	Atomisation & fan blanking plugs, replaces items (34) see exploded view.	
SPA-423-K	Atomisation & fan low profile control valve, replaces item (34) see exploded view.	
AGGS-33	Mounting bar.	
SS-659-CD	Mounting bar nut.	
SPA-173-K	Horizontal mounting bar and screws.	
SPA-174-K	Vertical mounting bar and screws.	
SPA-175-K	Mounting block and screws.	
SPA-176-K	Index adjustment and screws	



**DIMENSIONS**

**AG362- LEVER TYPE MANIFOLD**

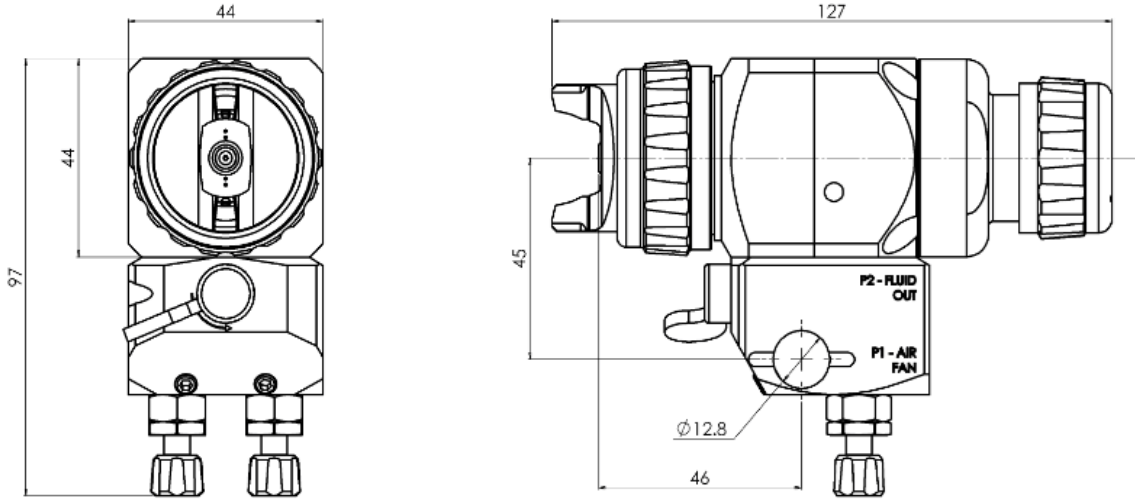

**AG362- SCREW TYPE MANIFOLD**

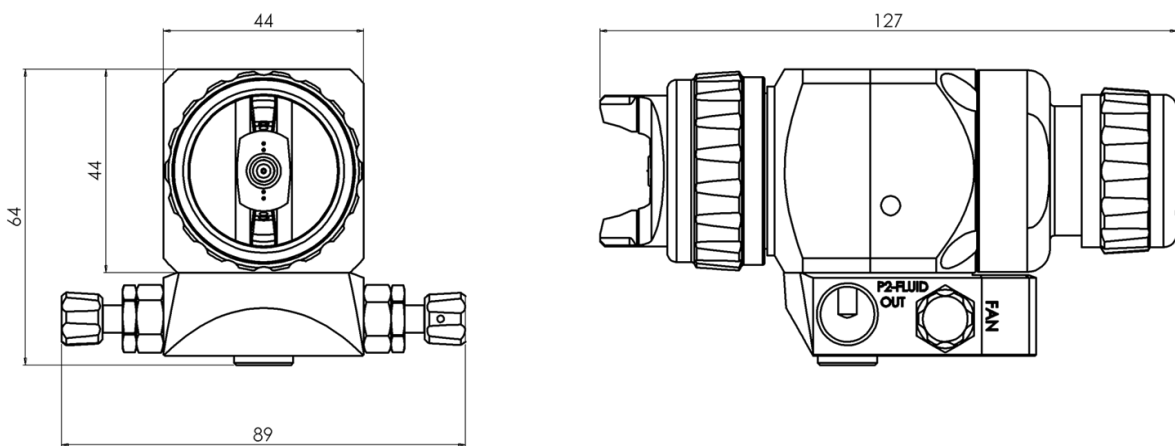

NOTES



## WARRANTY POLICY

DeVilbiss products are covered by Carlisle Fluid Technologies one year materials and workmanship limited warranty. The use of any parts or accessories, from a source other than Carlisle Fluid Technologies, will void all warranties. For specific warranty information please contact the closest Carlisle Fluid Technologies location listed below.

Carlisle Fluid Technologies reserves the right to modify equipment specifications without prior notice. DeVilbiss®, Ransburg®, MS®, BGK®, and Binks® are registered trademarks of Carlisle Fluid Technologies, Inc.

© 2017 Carlisle Fluid Technologies, Inc.  
All rights reserved.

DeVilbiss is part of Carlisle Fluid Technologies, a global leader in innovative finishing technologies. For technical assistance or to locate an authorised distributor, contact one of our international sales and customer support locations below.

### USA/Canada

www.devilbiss.com  
info@carlisleleft.com  
Toll Free Tel: 1-888-992-4657  
Toll Free Fax: 1-888-246-5732

### Mexico

www.carlisleleft.com.mx  
ventas@carlisleleft.com.mx  
Tel: 011 52 55 5321 2300  
Fax: 011 52 55 5310 4790

### Brazil

www.devilbiss.com.br  
vendas@carlisleleft.com.br  
Tel: +55 11 5641 2776  
Fax: +55 11 5641 1256

### United Kingdom

www.carlisleleft.eu  
info@carlisleleft.eu  
Tel: +44 (0)1202 571 111  
Fax: +44 (0)1202 573 488

### France

www.carlisleleft.eu  
info@carlisleleft.eu  
Tel: +33(0)475 75 27 00  
Fax: +33(0)475 75 27 59

### Germany

www.carlisleleft.eu  
info@carlisleleft.eu  
Tel: +49 (0) 6074 403 1  
Fax: +49 (0) 6074 403 281

### China

www.carlisleleft.com.cn  
mkt@carlisleleft.com.cn  
Tel: +8621-3373 0108  
Fax: +8621-3373 0308

### Japan

www.ransburg.co.jp  
overseas-sales@carlisleleft.co.jp  
Tel: 081 45 785 6421  
Fax: 081 45 785 6517

### Australia

www.carlisleleft.com.au  
sales@carlisleleft.com.au  
Tel: +61 (0) 2 8525 7555  
Fax: +61 (0) 2 8525 7575



*SOLUTIONS FOR YOUR WORLD*